

MLCS# 9467 Miter T-Fence Mounting Instructions

Make more accurate miter cuts and decrease tear-out with our precision extruded aluminum Miter T-Fence. Easily bolts to existing miter gauge for increased size (2-5/16" high by 22" long). Extension bar allows Maximum 36" length.

Mounting Methods

Note: Installing the Miter T-Fence onto MLCS Gauges (items #9456 or #9458) will not require a mounting block as shown below because these Miter Gauges have a "U" shaped channel to accept the mounting hardware. Other manufacturer's Miter Gauges may also have these "U" shaped channels or may even have through holes to correspond to the mounting hardware slot height on the MLCS #9467 Miter T-Fence. If your gauge differs, then use one of the other two mounting methods described below.

Slide the two hex head bolts into the T-Slots located in the back of the Miter T-Fence. Position the Miter T-Fence so that it will not contact the cutting blade when the Miter Gauge is pushed through its slot. The bolt should be seated into the "U" shaped slot in the Miter Gauge body. Secure the Miter T-Fence in place using a lock washer and star knob on each bolt.



Method 1: (See Figure A)

- 1) Make a mounting block of wood as follows: 2-1/4" high, 3/4" thick, 4" longer than your miter gauge face.
- 2) The block will require 2 (two) 1/4" holes positioned as follows: 1-1/2" from the bottom of the board and 1" from each end.
- 3) Draw a centerline on both the miter gauge face and your mounting block. Line up the lines and mount the block to the miter gauge using wood screws.
- 4) Insert the 1/4" hex bolts into the T-Slots located in the back of the Miter T-Fence and through the holes previously drilled in the mounting block. Secure with knobs.

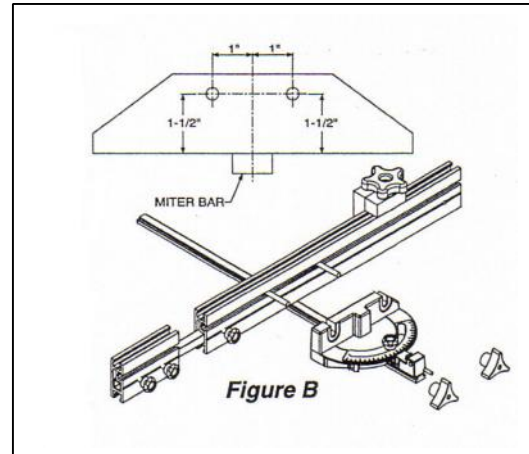
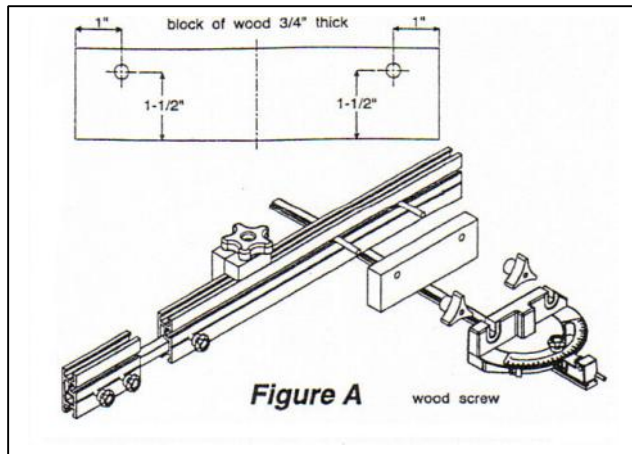

Method 2: (See Figure B)

- 1) Determine the center point of the miter gauge face and mark it.
- 2) Make a mark one inch to each side of the center line, 1-1/2" from the bottom of the miter gauge face, and drill 1/4" holes at these points.
- 3) Insert the 1/4" Hex Bolts into the T-Slots located in the back of the Miter T-Fence and through the holes previously drilled in the miter gauge face. Secure with knobs.

Installing the Miter T-Fence on a Miter Saw

- 1) Mark your Miter Saw Fence 2" and 6" from the outer edge and 1-1/2" above the miter saw table and drill 2 (two) 1/4" holes at the marks.
- 2) Insert the 1/4" hex bolts into the T-Slots located in the back of the Miter Fence and through the holes you just drilled. Secure with knobs.
- 3) Reposition the Miter Fence as needed. You will want your saw blade about 1/8" from the fence edge.

Constructing Table Support

- 1) Cut a 1/2" thick board to the width of your miter table.
- 2) Determine how far the Miter T-Fence goes beyond the end of the Miter Saw Table. Cut your board to that length.
- 3) On the back side of your board, drill 2 (two) 3/8" holes with a spacing of about 3".
- 4) Insert the two 3/8" Hex Bolts (not supplied) into the T-Slots located in the bottom of the Miter Fence and through the holes you just drilled. Secure with knobs.
- 5) Cut another board for the 4" extension and repeat steps 1-4.

NOTE: Since Miter Saws vary in size, the mounting hole placement may need to be adjusted accordingly.