

All varieties

MLCS is proud to offer an extensive variety of bits to make rail and stile frames for doors. These frames use “cope and stick” joints at the corners, which give a strong tongue and groove joint and a mitered molding look on the inside detail. A groove or rabbet is also created at the same time to hold a raised, flat, or glass panel.

Router: A reliable quality router will cost over \$120 and be worth every penny. MLCS carries bit sets for either 1/4” or 1/2” collets. The 1/2” collet is more versatile, because it accepts a wider variety of bits, including the larger 3 1/2” Raised Panel cutters. 1-1/2 to 2 HP is powerful enough for most work. In all cases, we strongly recommend being able to slow the speed of the router, either with **the MLCS #9000 or #9400 Router Speed Control** or one that is built into your router. This will enable you to better control the work piece and minimize burning on the more resinous woods such as cherry or maple. Speed control is especially important on less expensive routers, as bits can vibrate excessively at full speed. Finally, the router should be table-mounted. A sturdy, flat router table and a solid squared fence are important for producing quality doors. Routing rails and stiles freehand is **NOT** recommended.

Choosing Your Materials

Rails and Stiles: Wood for your rails and stiles should be straight-grained and knot free. Ends and edges should be square to the face of the wood. Consistent thickness throughout will save you hours of sanding later.

Raised Panels: Wood should be selected and glued up to best highlight a “cathedral” or “book-matched” grain pattern. For 3/4” thick stock, you may need to undercut the back of the panel to produce a 1/4” tenon. Choose a material for the panels. Solid wood is traditional, and must float free in the frame to allow for expansion. Solid wood panels must be “raised,” using one of a variety of MLCS Raised Panel bits.

For Painted Doors: MDF (Medium Density Fiberboard) is an excellent alternative to solid wood if you are painting your raised panel doors. It comes in large sheets, machines well, and will be less expensive than solid wood.

Using Flat Panels: 1/4” Plywood Panels in your rail and stile frame look nice in certain applications, and open up the possibility of a veneered panel. (See page 7).



Choosing a Bit or Bit Set

All styles make equally good cuts and joints. There are a variety of profiles and styles from which to choose. The rail and stile bits make a 3/8" wide profile, or a 3/8" deep rabbet in the case of the glass door bits. All the grooves for panels are 1/4" thick x 3/8" deep. (EXCEPTION: French Provincial Bit #8849 is 3/16" thick). The Window Sash (#8893, 8894), Miniature (#6548, 8848) cut a 1/4" deep profile and joint, and #8845 cuts a 7/16" deep joint.

Reversible Rail & Stile: The slot cutter, profile cutter, and bearing are assembled on a shaft in two different arrangements to produce the end cope and profile/groove cuts.

Matched Rail and Stile: Two separate bits make the required two cuts. No re-assembly needed.

Matched Miniature Rail and Stile: Two separate bits make the required cuts. Again, no re-assembly needed.

Stacked Rail & Stile: Two profile cutters, a slot cutter and a bearing stacked on a single shaft make both cuts by raising and lowering the entire assembly in the router table. (Available in 1/2" shank only)

Matched Entry Rail & Stile: A two bit set that cuts the profile detail on both sides of the wood with a slot between them. Use with 1-3/8" Stock for interior doors and 1-3/4" stock for exterior doors. (Available in 1/2" shank only)

Glass Door Reversible Rail & Stile: Same as the Reversible Rail and Stile, but with two slot cutters to produce a rabbet instead of a groove.

Window Sash/ Miniature Rail & Stile: Both bits work the same as the standard reversible bit, except these cut 1/4" deep instead of 3/8", and leave a rabbet for the glass. These are the best choice to make divided lite doors and mullions as they cut a narrower profile.

Shaper. Shaper versions of the bits work exactly the same as their router bit counterparts, but have three wing cutters and run at a slower speed.

Rails & Stiles

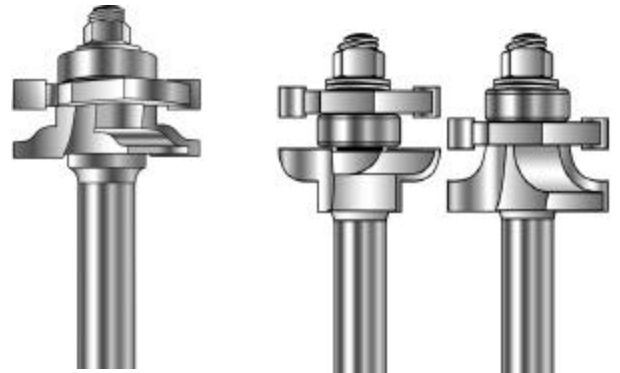

Reversible R & S

Matched R & S

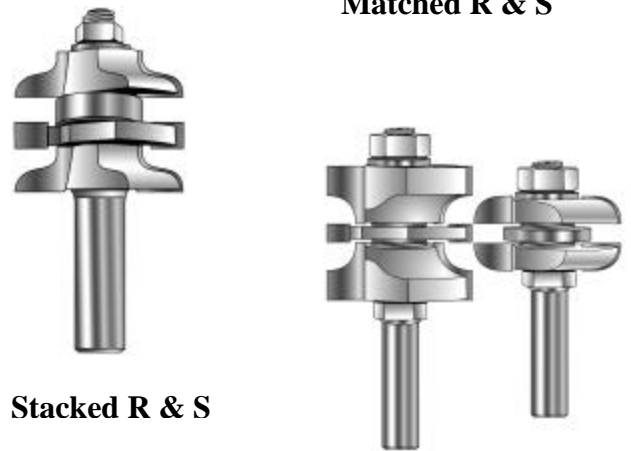

Stacked R & S

Matched Entry R & S

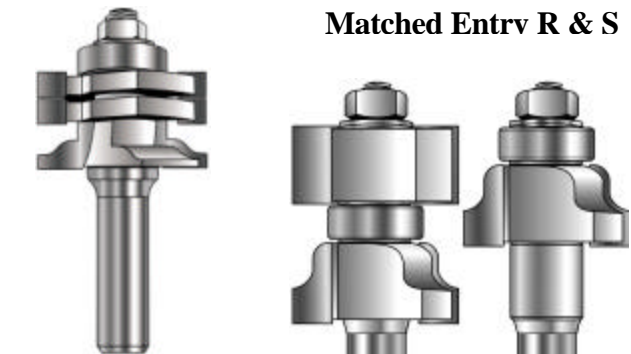

Glass Door Reversible Rail & Stile

Window Sash Set



Rail and Stile Shaper

Parts Preparation

Prepare enough wood for all of your rails and stiles, plus some test pieces. Decide how the door will sit in the opening: Flush, 3/8" Overlay, or Full Overlay (Fig. 6). The width of the parts depends on the design of the door. About 2 – 2 1/2" is average. **Woodshop Calculator (#9102/#9112)** can make your door planning easier to create perfect doors, using computer software.

RAILS: The rails (horizontal pieces) determine the width of the door and should be cut to exact length. Determine the rail width based on the width of the opening, the width of the stiles, and remember to add 3/8" on each side for the joint overlap. The ends of rails are known as tongue or "end cope" cuts.

STILES: The stiles (vertical pieces) can be left a little long to be trimmed after the door is assembled.

PANELS: Select and glue up solid wood panels at this time. Panel pieces should not be cut to exact size until the door frames can be dry-assembled for an exact measurement. The panel should be slightly smaller so it will "float" in the groove.

MAKING YOUR DOORS

If you are using a set-up block, refer to page 9 before continuing.

Reversible Rail & Stile: Start with the bit assembled in the tongue/"end cope" arrangement (Assembly A). You will find thin copper spacers with the bit--put them aside for the moment. Set the bit into the router table and adjust the height so that you get a complete cut on your stock. The exact measurement isn't critical. Set your router fence flush to the bearing. Select a test piece and feed the end through the bit, using your miter gauge or a "push block sled." Keep the piece square and look for a clean even cut.

IMPORTANT: When using 1/4" shank bits, always make 2 to 3 passes ending at the bearing.

Now re-arrange the bit into the "long" or profile cut (Assembly B).

Be careful--it is possible to assemble the cutters backwards. The flat side of the carbide should face into the cut. Do not change the fence; it is already set to the bearing. Adjust the height of the bit to match the previously-cut piece; then run second test piece. **If the fit is good, no shims are needed.** If the fit is too loose, go back to the first cut, add two shims above or below the bearing in the stack, and cut another tongue/"end cope" test piece. The shims can only widen the tongue on this end cope. Determine how many shims are needed (0-4) and note this for future reference. Finally, be careful not to over-tighten the top nut, as this will destroy the shims.

Fig. 6

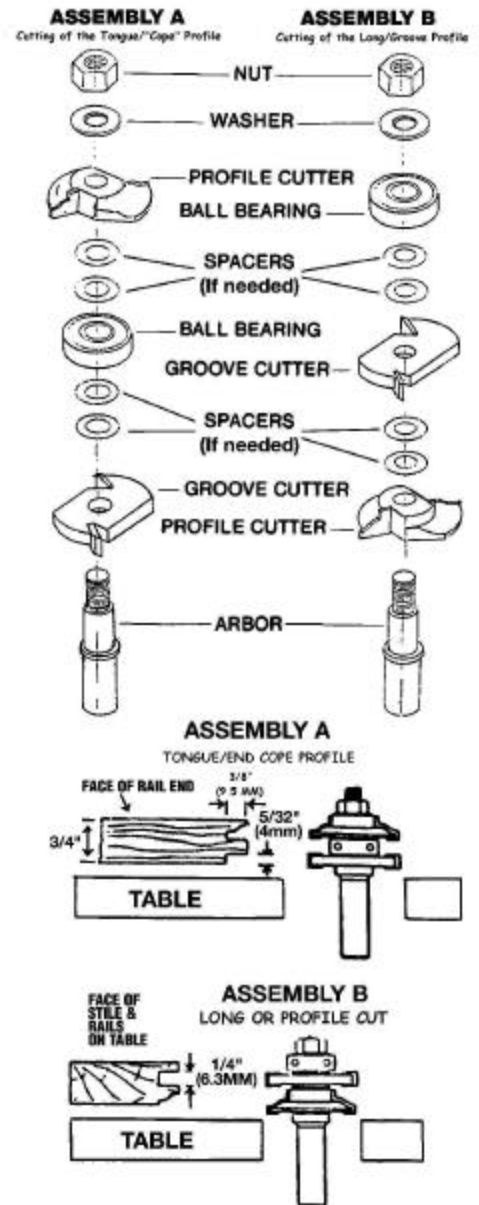
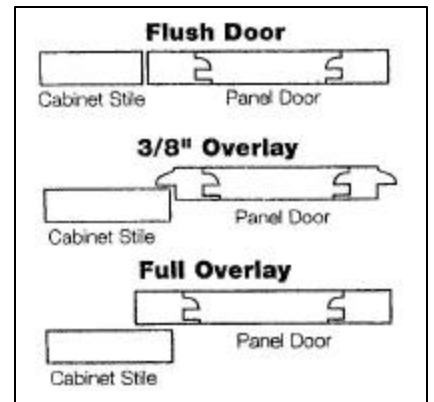

Rails & Stiles

The bit height adjustment will correct a “step” at the joint (**Figure 7**), assuming that your wood is of equal thickness. Set up and run all of one side of the joint (and maybe an extra or two); then run all of the other side. All of the rails and stiles for an entire kitchen can be cut in an hour or so.

Figure 7

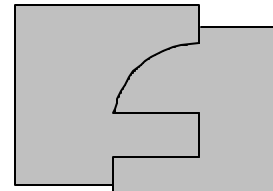

Rail and Stile Pointers and Problem Solvers

Tongue and Groove too tight or loose: On the rail end cope cut, add shims above or below the bearing to make the tenon thicker, thus tightening the joint. Remove shims to loosen.

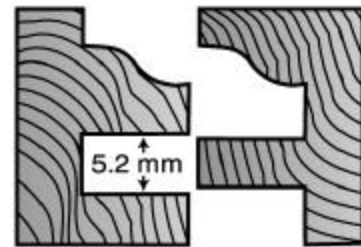

Misaligned Corners: 1) One wood piece may be thicker than the other. 2) Bit height is not correct. Double-check for accuracy.

Joint Doesn't “Match” Gaps Top or Bottom: Your wood end may be out of square with face. Check to see if you are cutting full depth of bit to bearing or your router is not square to the table.

Burning: Decrease router speed and feed work faster. Check the rail and stile bits to make sure the cutter is not reversed.

Matched Sets, Stacked, Entry and Shaper bits are all adjusted for fit and height exactly the same way.

Plywood Panel Conversion Kit #296

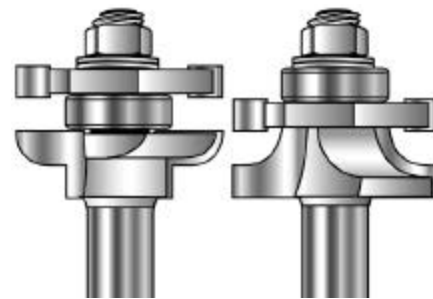

**Matched Rail and Stile
(Original Configuration)**

PLYWOOD PANEL CONVERSION KIT (#296):

Item #296 comes with two slot cutters allowing the user to quickly convert a matched Rail & Stile set from standard 1/4” joints to 5.2 mm in order to use European plywood for panels.

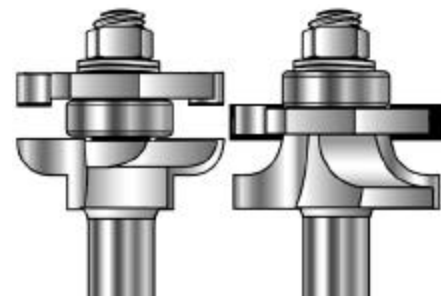

**Matched Rail and Stile Set with
Plywood Conversion Kit #296**

When changing bits for 5.2 mm use, one slot cutter has 5.2 mm teeth and one has 1/4” teeth. The 1/4” slot cutter **MUST** be installed on the Tongue or “End Cope” cutter. This will produce a 5.2 mm tongue. The 5.2 mm slot cutter is installed on the Rail and Stile bit to produce a 5.2 mm groove allowing the user to fit a 5.2 mm or European plywood panel in place of the standard 1/4” panel.

Rails & Stiles

Making Rail and Stiles with Rabbets

There are times when you need a rabbet instead of a groove in your door frame. Always do this for glass doors to allow for replacement. Stained glass, pictures, fabric panels, and many other materials are best installed in a rabbet, from behind, in a door frame. (Figure 8A)

Create a rabbet in a normal door frame by assembling the frame empty, running a 3/8" rabbeting bit around the back, then cleaning out the rounded corners with a corner chisel (MLCS Item #9541). If you need rabbeted frames regularly, choose one of the MLCS glass door assemblies, or a Window Sash bit. Use these bits just like the reversible styles, except install the spacer provided when making the end cope. (Fig. 8B)

Panels:

Dry assemble your Rail and Stile frames with clamps. Check the outside dimensions now. All MLCS bits make a 3/8" deep groove, but none of the panels should bottom out in the groove.

Remember! Size the solid wood panels to allow for expansion and contraction with the seasons. A 10" wide panel can move as much as 1/4" over the course of the year! Leaving 1/8" on each side for seasonal expansion is fine. Depending on the style of bit and thickness of wood, you may need to undercut the back of the panel to bring the tongue to 1/4" thick or make the panel flush to the frame. Check your dimensions **twice** and cut the panels to size.

Always run larger raised panel bits in a router table at a reduced speed (See page 3 for recommended speeds). Take light cuts by raising the bit or adjusting the fence (WARNING: When using a raised panel bit with an undercutter, do not attempt to raise the bit. You must adjust the fence back to make multiple passes when using a raised panel bit with an undercutter). 3 or 4 light passes will give the smoothest results. Some router tables do not have a large enough table opening for these large panel bits. Solve this by using a "false top" with a larger opening fastened down to the original table (Fig. 8C). This tip works for small fence openings too. Note: When using the raised panel bit with undercutter, the 3/4" thick panel may be proud (not flush) of the 3/4" thick rail and stiles, depending on the set up.

For a professional look, sand and finish the panel completely before assembly in the frame. Then, glue up the rail and stile frame, make any final size adjustments, and add the outside edge detail.

Figure 8A

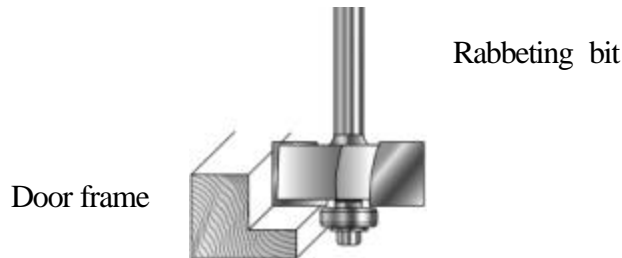

Figure 8B

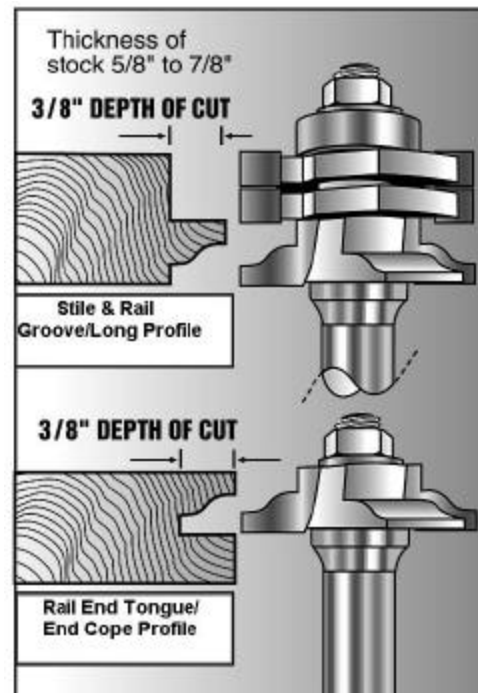
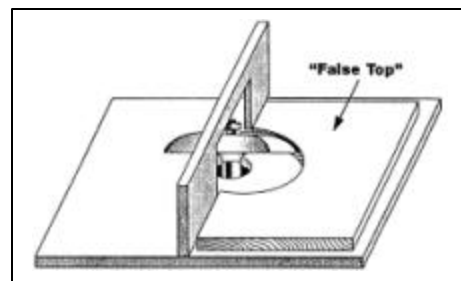

Figure 8C



**Set-Up Block
(Rail & Stile)**

Items #9741-9748
 #9790-9791

**USING SET-UP BLOCKS ON 3/4" THICK STOCK
(For Rail and Stile Doors)**

See pages 4-8 for instructions on how to use these router bits/shaper cutters. The stock you are using must be 3/4" uniform thickness for proper set up using the set-up block. We recommend that you start with the cope/rail end (tongue profile) first.

NOTE: the set-up block is not guaranteed to match the profile cut; it is guaranteed to allow the router bit/shaper cutter height to be set quickly and properly.

Install into your router/shaper table, the correct router bit/shaper cutter assembly to create the cope/rail end. Using the set-up block, raise or lower the cutting profile so it corresponds with the proper cut on the set-up block. **NOTE:** If you are using a safety coping sled (MLCS item #9495 or #9497), you must compensate for the thickness of the sled base when setting the router bit/shaper cutter height.



Using a piece of scrap stock, the same thickness as your rail/stile stock, make a test cut. For 1/4" shank router bits, adjust the fence to make the full cut in 3-4 passes; or, for 1/2" shank router bits or shaper cutters, adjust the fence to make the full cut in 1-2 passes. When making the final pass, the fence should be properly aligned with the router bit/shaper cutter by placing a metal straight edge across both the infeed and outfeed fences of the router/shaper table fences. The straight edge must also be in contact with the ball bearing guide/rub collar or smallest diameter of the carbide cutting surface if no ball bearing guide/rub collar is used. When you are satisfied that the cope/rail end cut is correct, proceed to make your actual cope/rail end cuts.



After you have completed the cope/rail end cuts, remove the router bit/shaper cutter assembly and install the correct router bit/shaper cutter assembly to make the stick/stile cut. Using the opposite side of the set-up block raise or lower the cutting profile so it corresponds to the proper profile cut on the set-up block. Now, using one of the rail pieces cut in the previous step, verify that the profile cut on the rail piece mirrors the cutting profile on the router bit/shaper cutter assembly. If the tongue on the rail piece and the slot cutter on the router bit/shaper cutter assembly are not exactly at the same height, adjust the router bit/shaper cutter assembly height accordingly.

Make another test cut, again using a piece of stock the same thickness as your rail/stile stock. Follow the same guidelines as you did when making the test cut in the rail piece. When you have completed this cut, test the fit against one of the cope/rail end pieces you have already cut. If the joint properly fits together and the height of the pieces properly align, proceed to make your actual stick/stile cuts.

NOTE: In order to get a proper joint, it is important to make sure that the router bit/shaper cutter assembly is cut the full depth to the ball bearing guide/rub collar. Also, your stock must be of uniform thickness and your height adjustment must be properly set.

Item #8845

MATCHED RAIL & STILE CUTTERS
FOR GLASS DOORS WITH
RECOVERABLE BEAD

***NOTE: Cut and rip the rails (horizontal pieces) to their finished length allowing 7/16" at each end to cope into stiles (vertical pieces).*

1. Use the router bit with profile cutter and bearing to make the cope cuts on the ends of your rail pieces (horizontal pieces).

2. Change to second router bit and adjust the bit height so that the bottom profile cutter matches the height of the profile cut on the ends of the rails when they are placed face down on the router table top. Because of the amount of material being removed, a better cut result may be achieved by making more than just one pass. Adjust your router fence between cuts until a straight edge touches both fence faces and the carbide at the innermost point between the bottom profile cutter and slot cutter.

3. After cutting the profiles on the inside of your rail and stile pieces, use a 1/8" straight bit, or a 1/8" kerf saw blade on your tablesaw, to remove the portion of the wood that protrudes further at the depth and distance of the slot.

4. Assemble and glue the rail and stile. When dry, measure for the glass panel, allowing 1/16" on all four sides for any seasonal wood movement. Place the glass panel into the door frame.

5. Measure and miter at 45 degrees the retaining strips removed in step 3 and secure them with brads—Do NOT glue them in place or you will not be able to replace the glass if it should break!! You may want to predrill the brad holes in the retaining strip to avoid splitting them while you are installing them. Be careful not to strike the glass while driving brads in.

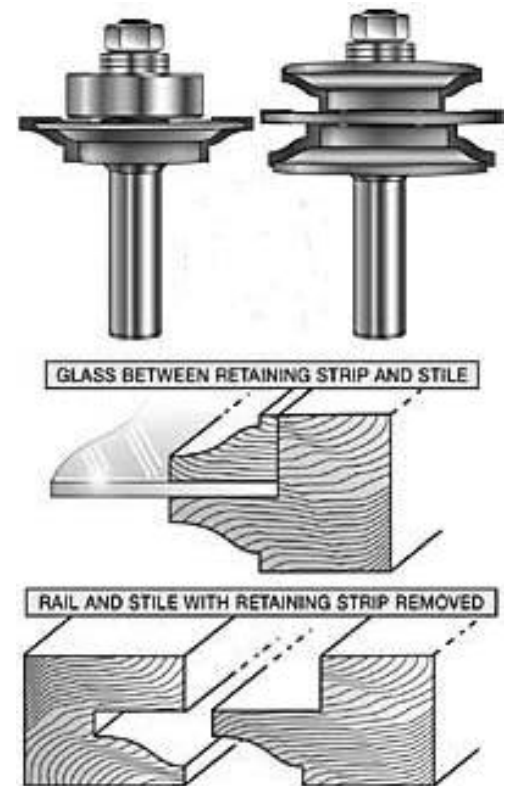

IMPORTANT POINTS

- ◆ Always use a router table and fence. These cutters should **NOT** be used freehand.
- ◆ Cutters should **ALWAYS** be run at a **REDUCED SPEED**. Use the **MLCS #9000 or #9400 Speed Control** or a variable speed router.
- ◆ This bit set comes assembled for making a 1/4" tongue and slot. If you are going to make a 1/2" tongue and slot, make sure to replace both the slot cutter and spacer/rub collar or your rails and stiles will not properly match up.
- ◆ Check the top nut when you first receive your cutters and periodically with use. The nut should be very snug, but not over-tightened. This will destroy the adjustment shims.
- ◆ Use Push Blocks (**MLCS #9138, 9139, 9140**) and a miter gauge or sled to feed your rails and stiles. **NEVER** use fingers to feed narrow stock!
- ◆ A 1-1/2 HP **PROFESSIONAL QUALITY** router will cut the profile in one pass. You can make the cut in 2 passes in difficult wood by adjusting the fence.

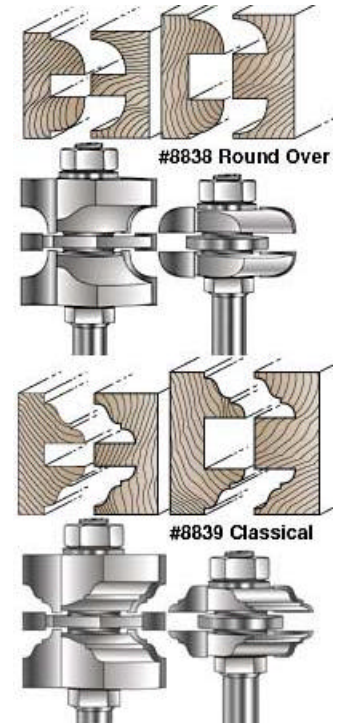

DESIGN AND CONSTRUCTION

- ◆ The cope and stick corner created by the bits is not strong enough by itself for a full-sized door. Our favorite method for reinforcing the corners is to assemble the door, then drill through the outside stiles and add screws or dowels into the rails.
- ◆ Glass panels can be made by assembling the door then routing out the profile on one side with a 3/8" Rabbeting Bit. Clean up the corners with a chisel, then make a small piece of molding to hold the glass in place.
- ◆ Panels for the door can be made using any of the MLCS Raised Panel bits. They can be "raised" on one or both sides. Depending on the profile you select, you may have to adjust the thickness of the panel stock so you end up with a 1/4" or 1/2" tongue to fit the frame groove. You can also use 1/4" or 1/2" thick veneer plywood for flat panels.
- ◆ **NOTE:** Veneer plywood will be a true 1/4" or 1/2" while cabinet grade plywood may be up to 1/32" undersized on the thickness, possibly leaving a loose, rattling panel.