

## Lock Miter

Bits #5547, 5548, 7847, 7849, 7850  
 KATANA Bits #17849, 17850

The Lock Miter bit makes clean, self-aligning mitered corners in hardwood, softwood, and plywood. Choose your bit based on the thickness of the material you plan to use, following the catalog specs. The bit must be used in a router table with a straight, squared fence. Best results are obtained with minimum clearance around the bit both in the table and fence. A variable speed router or **Router Speed Control (MLCS Item #9000 or #9400)** will make the job easier.

The Lock Miter bit uses only one set-up for both sides of the cut. **The most important thing to remember when adjusting the bit is this:** The bit should be centered on the stock and be an equal distance from the top to the bottom, and only the diagonal of the bit should show.

*If you are using a set-up block, refer to pages 28-29 before continuing.*

Prepare some test wood the same thickness as your project, about 6" wide and cut square and true. Do not pre-miter the ends of the work. The bit does this. At the ends of the test pieces to be cut, attach a scrap of wood, as shown below, along the cut to act as a guide against the fence and table. Once the actual workpiece clears the bit, there is only a point of the piece left to ride the fence or table. The scrap piece keeps the work running straight and true. Run one side of the joint down on the table, then run the other side upright against the fence. Remove the scrap pieces and check the fit. Make a minute adjustment in the height of the bit or the depth of cut to align the corner, then run all of your corner pieces.

**TIPS:** Use double-faced tape (MLCS Item #9489 or #9493) to fasten the scrap pieces to all of the ends of the workpieces at once. Make them about an inch longer at each end for good stability. The **Merle Adjustable Corner Clamp (MLCS Item #9012)** is the best choice for gluing up a lock-mitered box.

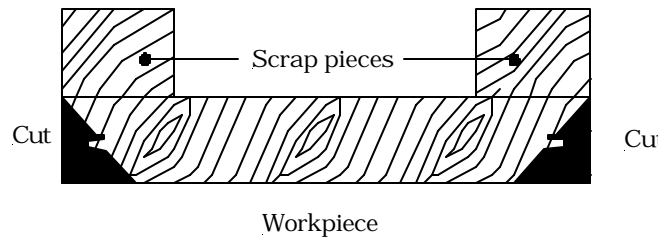
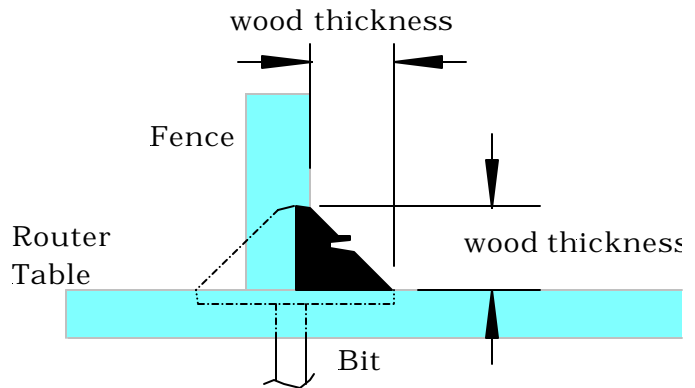
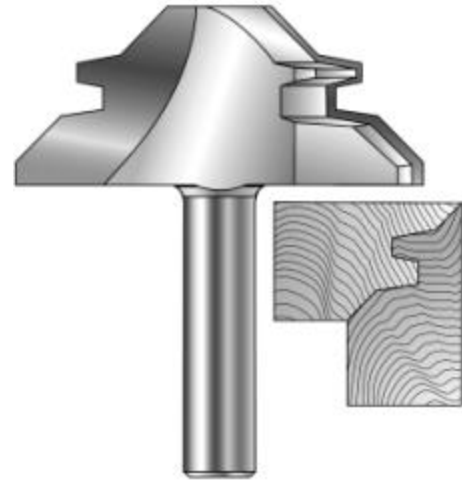



## Lock Miter

If you experience excessive tear-out due to grain orientation or when using some plywoods, follow these steps in an attempt to eliminate this situation.

After following the set-up and testing instructions, and when you are satisfied with the fit of your Lock Miter joints proceed by:

1. Clamp a long stop block (preferably close to length of your fence) securely and snugly behind the back of your fence assembly. (You will be moving the router table fence and this will allow to return the fence to it's proper position for your final pass).
2. Slide the fence forward exposing only 1/4 to 1/3 of the router bit. Secure in place.
3. Make the cuts on your stock with the fence secured in this forward position. When completed loosen the fence.
4. Slide the fence backward toward the stop block, exposing more of the router bit. Again make the cuts on your stock with the fence secured at this new position. (Repeat as needed until the fence is once again positioned against the stop block. Multiple shallow cuts will yield a cleaner cut with less chance of tear-out).

## Setup Block for Lock Miter Bit

### USING SET-UP BLOCKS ON 1/2", 11/16" and 3/4" THICK STOCK \* (For Lock Miter Joints)

Items #9751, #9753, #9754, #9755

See pages 26-27 for instructions on how to use these bits. The stock must have 1/2" or 3/4" for #9751, #9753 and #9754 or 11/16" for #9755 uniform thickness. Use the miter end of the set-up block with the flat edge for 1/2" stock and the full 45-degree miter end of the set-up block for 3/4" stock.

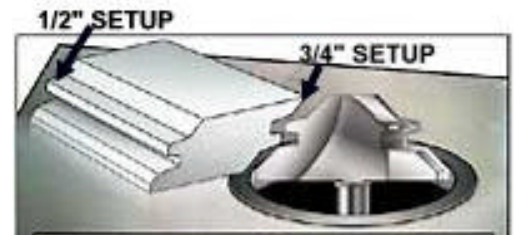

Using the set-up block, raise or lower the bit until the block aligns with the tongue and groove of the bit. (Note: the set-up block is not intended to match the profile cut; its purpose is to allow the bit height to be set quickly and properly). Move your router fence in until the setup block contacts both sides of your router fence.

Make sure the speed of the router is about 12,000-14,000 rpm. Test cut a piece of stock using extra or scrap wood.

Fit together and check for surface and joint match. You may have to fine tune the joint after testing your first cut to get a perfect fit, by either adjusting the fence in or out, or adjusting the bit height up or down. Remember any adjustment will be doubled on the cut. (for example, if you adjust the bit up or down by 1/32", then the joint will be different by 2/32" or 1/16")



Once you have a perfect fit with your extra or scrap wood, you are ready to make the lock miter joint with your good stock.

**NOTE 1:** If the joint is good, but the surfaces are not even or the miter portion has a square edge, you must adjust the height of the bit upward or downward.

**NOTE 2:** If you have a split fence, close the opening as much as safe operations, permits.

*\* The set-up block is approximately 3/4". If your wood does not match the set-up block size:*

- Plane the wood to match the set-up block, if possible.
- If the wood is thicker than the set-up block, raise the bit and push the fence back slightly, until a good fit is obtained.
- If the wood is thinner than the set-up block, lower the bit and move the fence forward slightly, until a good fit is obtained.

## Setup Block for Lock Miter Bit

### USING SET-UP BLOCKS ON 3/8" and 1/2" THICK STOCK \* (For Lock Miter Joints)

Items #9750

See pages 26-27 for instructions on how to use this bit. The stock must have 3/8" or 1/2" uniform thickness. Use the miter end of the set-up block with the flat edge for 3/8" stock and the full 45-degree miter end of the set-up block for 1/2" stock.

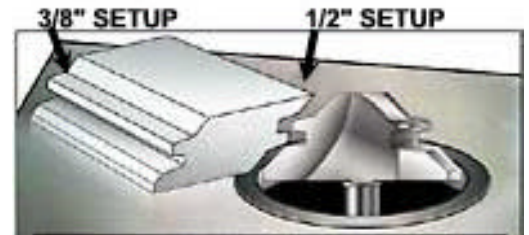

Using the set-up block, raise or lower the bit until the block aligns with the tongue and groove of the bit. (Note: the set-up block is not intended to match the profile cut; its purpose is to allow the bit height to be set quickly and properly). Move your router fence in until the setup block contacts both sides of your router fence.

Make sure the speed of the router is about 18,000 rpm. Test cut a piece of stock using extra or scrap wood.

Fit together and check for surface and joint match. You may have to fine tune the joint after testing your first cut to get a perfect fit, by either adjusting the fence in or out, or adjusting the bit height up or down. Remember any adjustment will be doubled on the cut. (for example, if you adjust the bit up or down by 1/32", then the joint will be different by 2/32" or 1/16")



Once you have a perfect fit with your extra or scrap wood, you are ready to make the lock miter joint with your good stock.

**NOTE 1:** If the joint is good, but the surfaces are not even or the miter portion has a square edge, you must adjust the height of the bit upward or downward.

**NOTE 2:** If you have a split fence, close the opening as much as safe operations, permits.

*\* The set-up block is approximately 1/2". If your wood does not match the set-up block size:*

- Plane the wood to match the set-up block, if possible.
- If the wood is thicker than the set-up block, raise the bit and push the fence back slightly, until a good fit is obtained.
- If the wood is thinner than the set-up block, lower the bit and move the fence forward slightly, until a good fit is obtained.